

WATER MONKEY

WATER MONITORING SOLUTION

The Water Monkey is a battery-powered water monitoring device that also detect leaks. The Water Monkey operates autonomously over LTE-M or NB-IoT wireless networks and is compatible with almost all meter makes and models. The Water Monkey analyzes your water consumption behavior patterns and uses its Artificial Intelligence and Machine Learning algorithms to detect leaks and unusual flow rates.

The Water Monkey gives you granular water insights and detects leaks and pipe bursts to help reduce your water risk while simultaneous alerting you of leaks that otherwise go undetected and may cost you a pretty fortune.

KEY FEATURES

- ✓ AI algorithm - monitors, learns, & adapts
- ✓ Real-time email, SMS, & telegram alerts
- ✓ Water & tamper proof
- ✓ Easy install - No wiring or pipe cutting
- ✓ Integrates with existing infrastructure
- ✓ Compatible with all meter makes and models
- ✓ Day, time, and volume threshold alerts
- ✓ One device supports up to 2 meters



WATER MONKEY

TECHNICAL SPECIFICATIONS

MECHANICAL PROPERTIES & WARRANTY

SMA-RF Connector for external Antenna
3-Pin Remote Smart Pulse Head connector
Blue Status Indication LED
IP54 Enclosure
Glass Reinforced Nylon Composite Material
Kevlar Reinforced Velcro Straps
2 Year Limited Warranty

CHIPSET & MEMORY

ARM Cortex M33
1MB Flash
256kB RAM
4MB of space for local logging

SUPPORT NETWORKS

3GPP LTE release 13 Category M1 and NB1 compliant
3GPP release 14 NB2 compliant
Supports 4FF Nano SIM

POWER REQUIREMENTS

3.6V primary cell battery pack
12000mAh battery
Lithium Thionyl Chloride (Li-SOC12)
2-5 years (installation dependent)

FC / IC REGULATION

Contains FCC ID: 2ANPO00NRF9160
Contains IC: 24529-NRF9160
CAN ICES-3 (B)/NMB-3 (B)

ANTENNA PERFORMANCE

Antenna Type: Whip, Tilt/Swivel • Number of Bands: 6
Frequencies: 600MHz, 700MHz, 800MHz, 850MHz, 900MHz, 1.575GHz, 1.7GHz, 1.8GHz, 1.9GHz, 2.1GHz, 2.3GHz, 2.5GHz, 3.3GHz, 3.5GHz, 3.7GHz

SUPPORTED BANDS

Cat-M1: B1, B2, B3, B4, B5, B8, B12, B13, B14, B17, B18, B19, B20, B25, B26, B28, B66
Cat-NB1/NB2: B1, B2, B3, B4, B5, B8, B12, B13, B17, B18, B20, B25, B26, B28, B66

DIMENSIONS & FEATURES

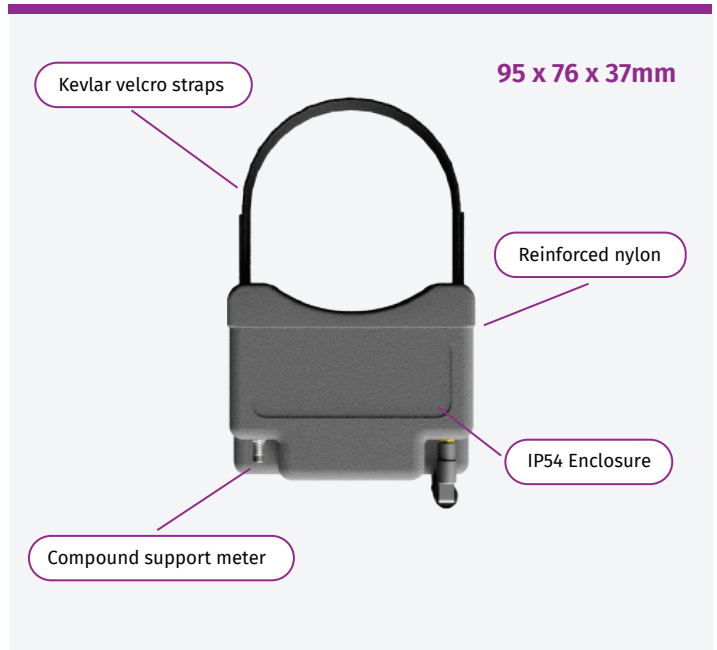

RELATED PRODUCTS

ODEUS Water Monitoring
Water Consumption Audit



SMART PULSE ADAPTER

WATER MONKEY COMPOUND METER ATTACHMENT

The SmartPulse converter is intended to be used in conjunction with the Water Monkey to enable the monitoring of dual head or compound water meters. The SmartPulse adapter deploys an Always-On active detection algorithm that is capable of detecting pulses from a variety of industry standard water meters and features an easy install self-calibration feature.

KEY FEATURES

- Dual head or compound meter support
- Always on active water detection
- Compatible with various meter sizes

TECHNICAL SPECIFICATIONS

- IP Rating: IP65
- Cable Length: 300mm
- Material: Glass Reinforced Nylon PA12

DIMENSIONS

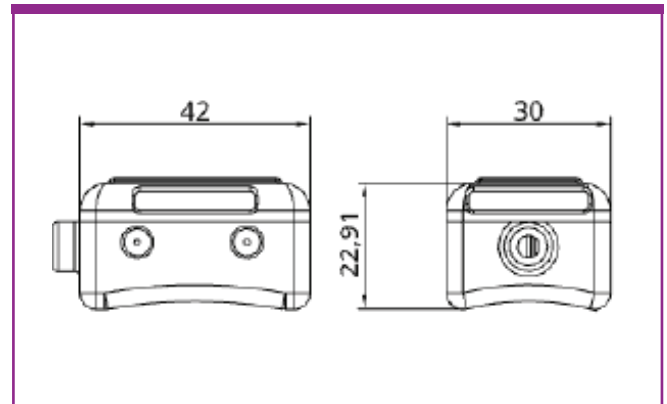



CONNECTED SENSORS